

P226 Exploded diagram

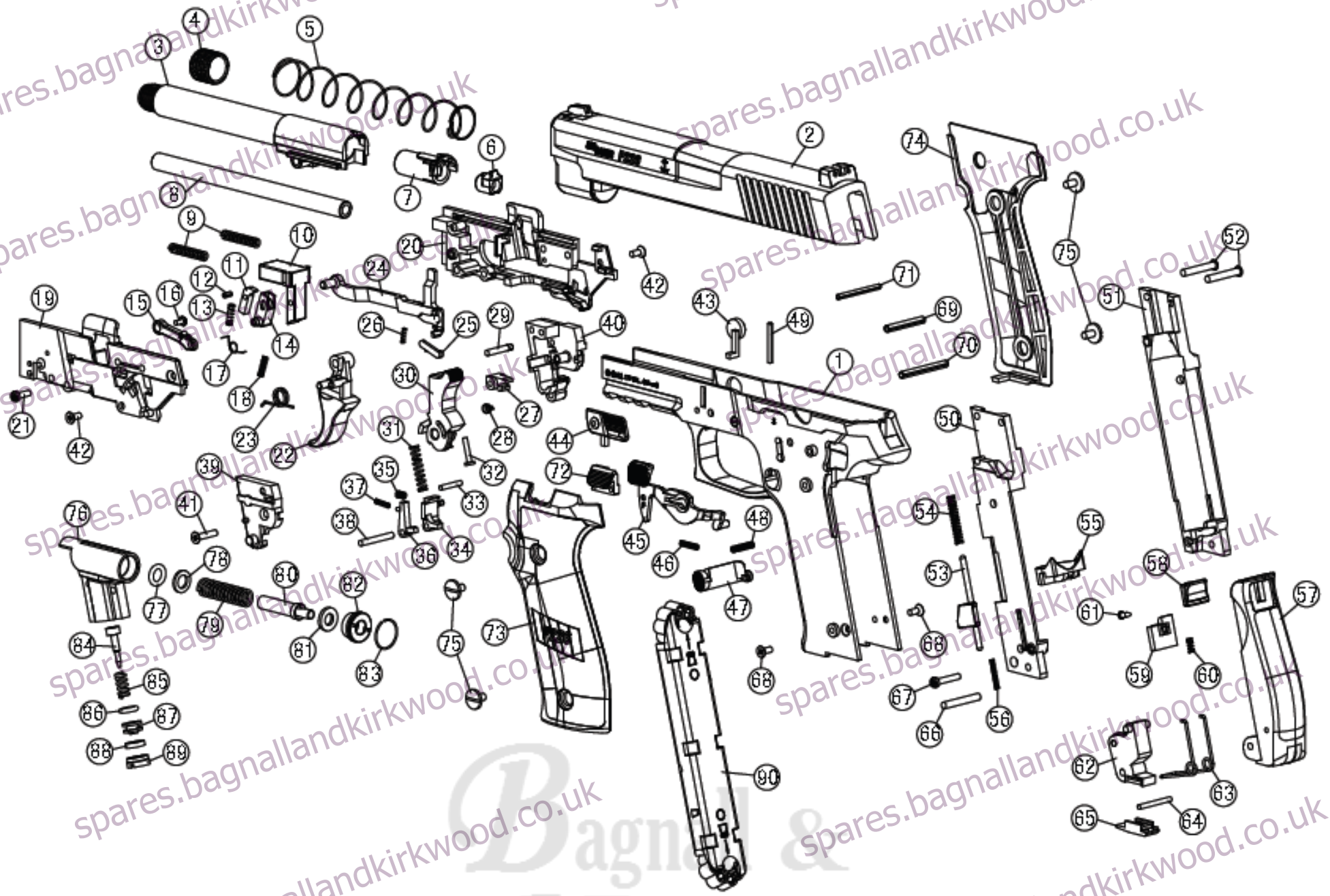

1. Frame	26. Trigger Bar Plunger Spring	51. Puncture Frame Right	76. Valve Body
2. Slide Assembly	27. Hammer Block Piece	52. Valve Body Pin	77. O-ring P-6 Urethane
3. Outer Barrel	28. Hammer Block Piece Spring	53. Magazine Release	78. Valve Washer
4. Muzzle Cap	29. Hammer Block Piece Pin	54. Magazine Release Spring	79. Valve Spring
5. Recoil Spring	30. Hammer	55. Cylinder Base	80. Valve Pin
6. Chamber Sleeve	31. Hammer Spring	56. Cylinder Base Spring	81. Valve Seal
7. Outer Barrel End	32. Hammer Spring Guide	57. Back Grip	82. Valve Cap
8. Inner Barrel	33. Hammer Spring Pressure Pin	58. Grip Switch	83. Piston Ring
9. Buffer Spring	34. Sear	59. Grip Switch Nail	84. Pierce Pin
10. Slide Block	35. Sear Spring	60. Grip Switch Spring	85. Pierce Spring
11. Nail	36. Inner Safety	61. Grip Switch Screw	86. O-ring P-5 Urethane
12. Nail Pin	37. Inner Safety Spring	62. Puncture Clamp	87. Pierce Ring
13. Nail Spring	38. Sear Pin	63. Puncture Clamp Spring	88. Pierce Seal
14. Nail Base	39. Hammer Base Left	64. Puncture Clamp Spring Pin	89. Pierce Cap
15. Nail Arm	40. Hammer Base Right	65. Puncture Clamp Bottom	90. Magazine
16. Nail Arm Screw	41. Hammer Base Screw (Long)	66. Puncture Clamp Pin	
17. Nail Base Spring	42. Hammer Base Screw (short)	67. Puncture Frame Screw	
18. Nail Arm Spring	43. Dummy Take Down Lever Right	68. Frame Screw	
19. Mechanism Frame Left	44. Dummy Take Down Lever Left	69. Mechanism Frame Pin (short)	
20. Mechanism Frame Right	45. Safety Lever	70. Mechanism Frame Pin (long)	
21. Mechanism Frame Screw	46. Safety Lever Spring	71. Slide Block Pin	
22. Trigger	47. Magazine Catch	72. Dummy Slide Stop	
23. Trigger Spring	48. Magazine Catch Spring	73. Grip Left	
24. Trigger Bar	49. Magazine Catch Pin	74. Grip Right	
25. Trigger Bar Plunger	50. Puncture Frame Left	75. Grip Screw	